

The World's First Mobile Fall Arrest Anchor Filled with Water



Introducing the **ecoAnchor** from CHECKMATE SAFETY - a specialist designer and manufacturer of height safety equipment.

The device is a totally unique concept in fall protection and uses renewable resources for both manufacture and installation. The anchor is constructed of a special natural rubber material that holds the bag in a solid cube form when filled with just water.

The **ecoAnchor** is compatible with a large variety of roof surfaces including composite and mineral felts. It has been tested to exceed the EN795 class E standard and is suitable for use on pitched roofs of up to 15 degrees.

When collapsed, the **ecoAnchor** weighs just 8kg, fitting into a small bag, and avoiding the need to transport, or carry, heavy weights to the top of a building prior to installation.

Patent Pending No. 0901634.6



FAB's, rope grabs and lanyards

Collapsed ready to stow

Lightweight and easy to fold and roll



Fits in small carry bag

Simple hose connector for filling

Vent to ensure correct pressure



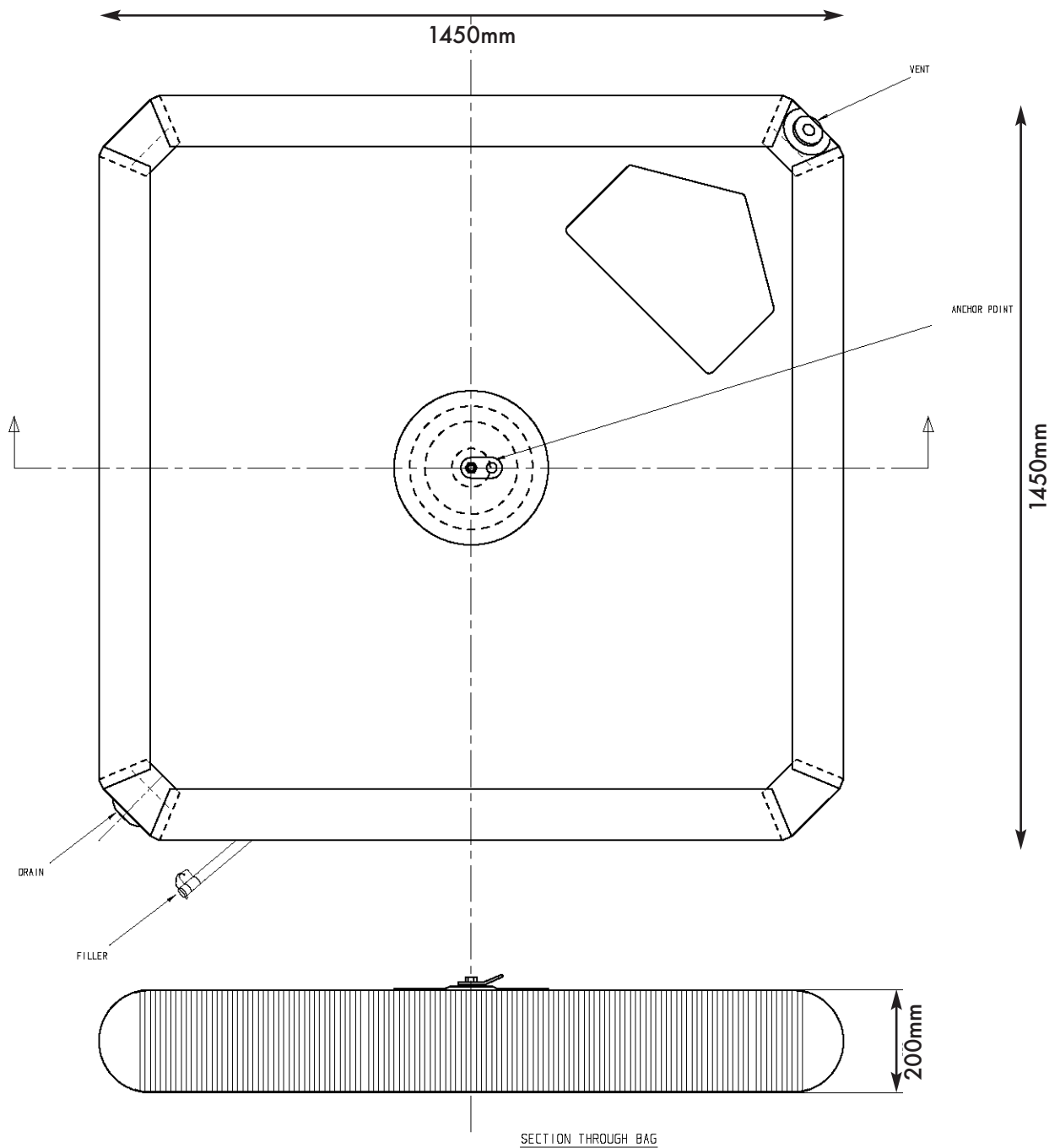

Designed and Manufactured by:



CHECKMATE
SAFETY

Checkmate Lifting & Safety LLP,
Sheerness, Kent. England.
ME12 1PZ, UK
Tel: +44 (0)1795 580333
Fax: +44 (0)1795 668280
sales@checkmateuk.com
www.checkmateuk.com

Principal Features

- **Material**
Fire resistant Neoprene® re-enforced with Nylon
- **Dimensions**
1.45mx1.45mx0.2m (4' 9" x 4' 9" x 8") Nominal
- **Weights**
Empty=8kg (17lbs) Full=430kg (946 lbs)
- **Pressure loading**
2.7kN/m² (0.42lbs/Inch²)
- **Puncture resistance**
Meets FED STD 191 Part 1520
- **Roof types**
EPDM, Mineral Felts, Concrete and Metal Deck
(full test report available on request)